

RCV60SP Exploded Parts View

RCV engines are inherently reliable, however as with all engines spares will sometimes be required. If you need to order any spares you can do so either from your local hobby shop or from RCV direct. A list of available spares can be found on the RCV web shop. When ordering spares please include the serial number of your engine. Some components below are only available as complete assemblies to enable RCV to keep our spares at the lowest possible prices. If you need different spares or would like help in identifying a spare please contact RCV.

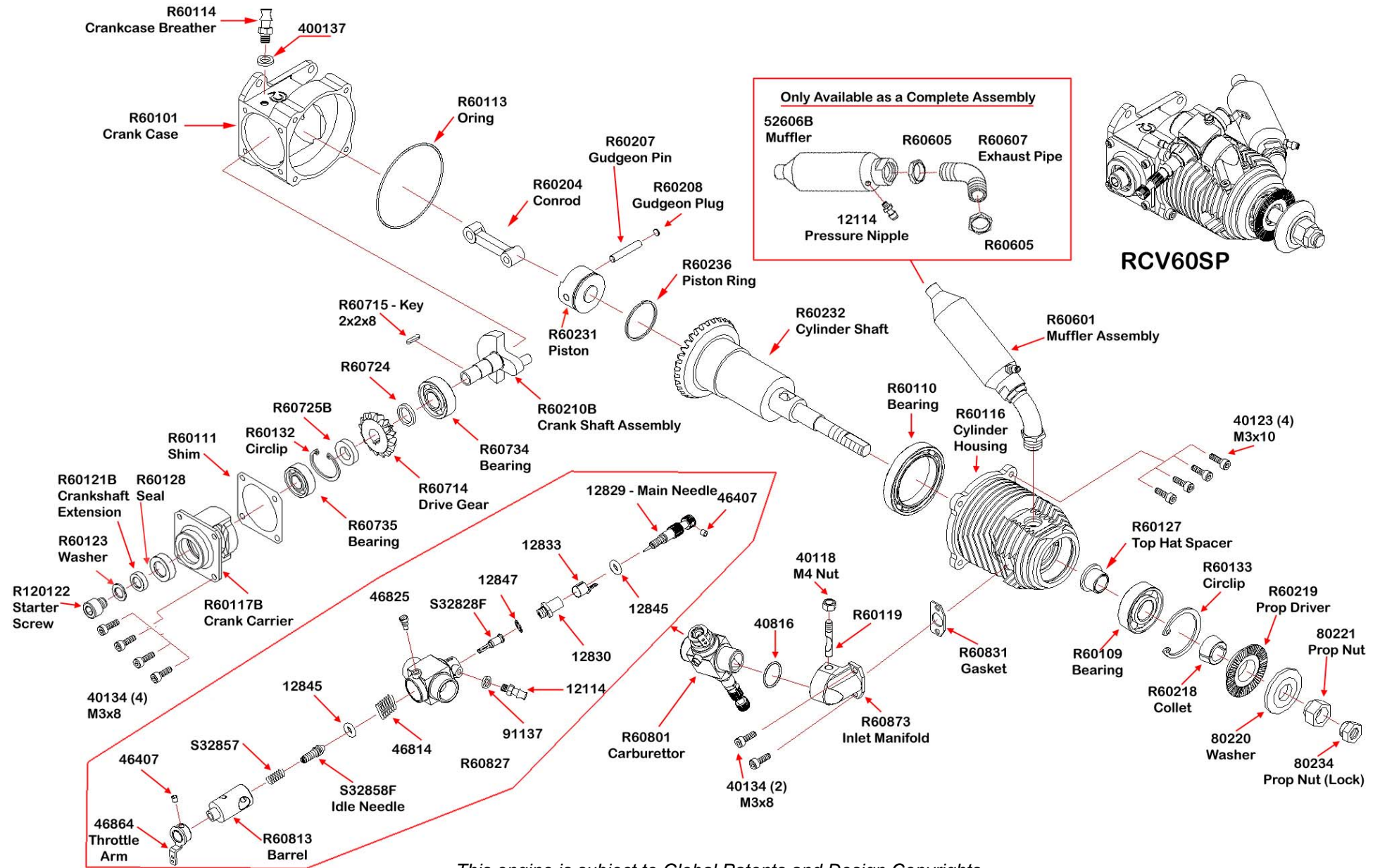

This engine is subject to Global Patents and Design Copyrights

RCV60SP - Engine Dimensions

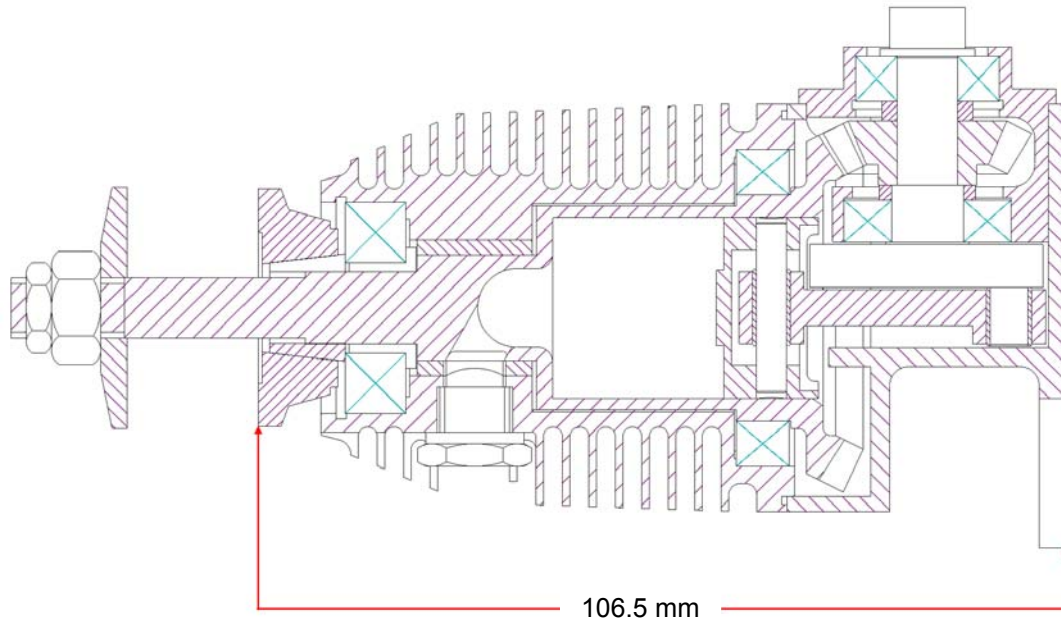

Centre Line for Mounting

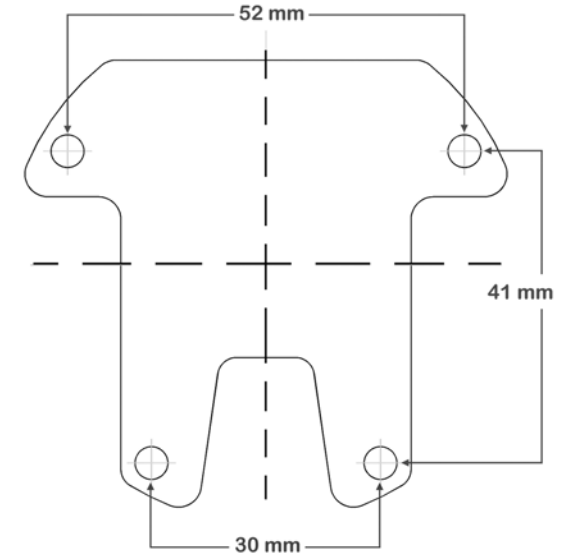

To assist you with mounting, please use the template above.
Cut this out and line up with your engine.
Then simply mark through the centre directly onto your engine backplate.

RCV60-SP Specifications

	Displacement	Weight inc. silencer	Prop Shaft Dia	Exhaust Thread	Practical rpm @ prop	Cowling clearance	2-blade Prop sizes	3-blade Prop sizes	4-blade Prop size	Glow Plug	Approx. fuel consumption
Imperial	0.6 cu in	21.93 oz	5/16" UNF	M10 x 0.75	1400 - 6000 rpm	R36	14x14, 15x14, 16x12, 16x14	13.4x13.5 15x13W 15x13.5	13x13 14.5x11	OS 'F'	> 0.4 fl oz/min
Metric	10 cc	605 g									

RCV Engines Ltd

4 Haviland Road, Ferndown Industrial Estate, Wimborne, Dorset, BH21 7RF, UK

Tel: +44 (0)1202 877044 Fax: +44 (0)1202 871836 Email: sales@rcvengines.com www.rcvengines.com